



ANCHOR / MICROPILE FOUNDATION DRILL RIG

Reference Manual

Abstract

The ADSC - The International Association of Foundation Drilling in association with the NCCCO is proud to bring you this reference manual to assist you in your preparation for the NCCCO Foundation Drill Rig Operator Certification Exam.

Special thanks go to the members of the NCCCO Foundation Drill Rig Task Force for their cooperation in the development of this resource.

Rick Marshall
Director of Safety - ADSC

Table of Contents

Introduction	5
Definitions	6
Project Planning	7
General	7
Training of Employees	7
Site Management	7
Safety Management	8
Foundation Technique Selection	8
Design of Working Platforms	9
General Requirements for Anchor/Micropile Drill Rigs.....	11
Operator Training Requirements	11
Intended Use of the Anchor/Micropile Drill Rig	11
Ergonomics.....	11
Hot & Cold Surfaces and Sharp Edges.....	11
Ventilating Ports	11
Hoses, Pipes and Fittings Under Pressure	11
Handling of the Drill Rig and Its Parts	12
Access to Operating Positions and Servicing Points.....	12
Isolation of Energy Sources.....	12
Driving, Tramming and Operating Position.....	13
Operator’s Position	13
Controls, Functions, Systems	14
Starting.....	14
Stopping.....	14
Normal Stopping.....	14
Emergency Stops	14
Failure of the Power Supply	15
Failure in a Control Circuit	15
Control Devices	16
General.....	16
Stability.....	18
General Stability Criteria	18

Dynamic Forces	19
Wind Force	19
Other Working Forces	19
Operating Conditions	19
Stability of Anchor/Micropile Drill Rigs.....	20
Service Braking Systems on Crawler Mounted Drill Rigs.....	20
Protection Against Moving Parts.....	21
General.....	21
Danger Zones.....	21
Electric Power Installation	21
Severe Weather	22
Battery Installation	22
Hydraulic Systems	23
Auxiliary Winch	24
Feed Chain.....	24
Warning devices.....	26
Set-up and Operation	27
Location.....	27
Locating Underground Utilities	27
Equipment	28
Loading - Unloading Equipment	29
Assembly and Disassembly of Anchor/Micropile rigs.....	29
Exclusion Zones	30
Powerlines and Electrical Equipment.....	31
Overhead Powerline Safe Working Clearance:.....	31
Equipment, Inspection and Maintenance	33
General.....	33
Pre-Operational Inspection.....	33
Routine Maintenance	34
Annual Inspection.....	35
Competent Person for Inspection	35
Repairs	35
Welding.....	36
Equipment Modifications	36

Maintenance Records.....	36
Drilling Operations	38
Drilling Equipment Using Threaded Drill String Connections	38
Clamps and Rod Breaking Clamps Used in the Drilling Process.....	39
Falling or Ejected Objects.....	39
Safety Device for Stopping of Rotation and Feed	39
Field Operations - General	41
Drilling.....	42
Considerations during general operation:	42
Considerations when adding and removing drill rod:	43
Operating the Drilling Rig	43
Working on the Mast - General Repairs.....	44
Pressurized Systems	44
Acknowledgments:	45
Appendices:	46
Resource Material Available Without Cost:	49
Overhead Powerline Safe Working Clearance:	49
Underground Utility Location:	49
Rotary Foundation Drilling Rig Safety:.....	49
Construction Safety Regulations:	50
OSHA - Occupational Safety & Health Administration	50
US Army Corps of Engineers Safety and Health Requirements Manual	50
The Federation of Piling Specialists	50
The National Institute for Occupational Safety and Health (NIOSH).....	50
Canadian Centre for Occupational Health and Safety - Links to Provincial Requirements	50
Canada National Occupational Health and Safety Regulations	50
Education:	50
Rigging Information:.....	50
Crosby Group	50
National Commission for the Certification of Crane Operators (NCCCO) Reference Manuals	50
.....	50
Resource Material Available for Purchase:	51
European Standards:	51
EN 16228-1 Drilling and foundation equipment - Safety - Part 1 - Part 7.....	51
American Society of Safety Professionals (ASSP):.....	51

ANSI/ASSE A10.23-2014 - Safety Requirements for the Installation of Drilled Shafts 51
ADSC: The International Association of Foundation Drilling: 51

Introduction

The term “Anchor/Micropile Foundation Drill Rig” covers several differing types of machines for use in the deep foundation construction industry. This guide is intended to cover those foundation drill rigs used for the installation of earth anchors, rock anchors, micropiles, soil nails, and comparable products. It addresses many of the most common hazards associated with mechanized drill rigs when they are used as intended by the manufacturer. See the following examples of Anchor/Micropile Foundation Drill Rigs:

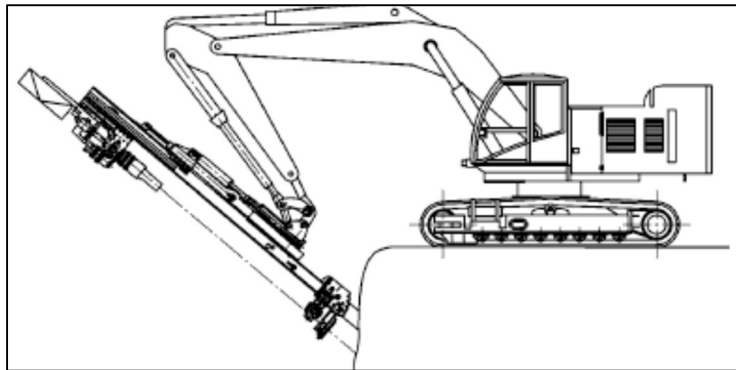
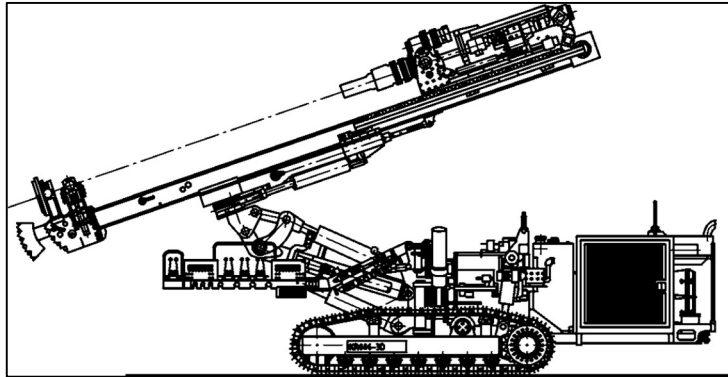
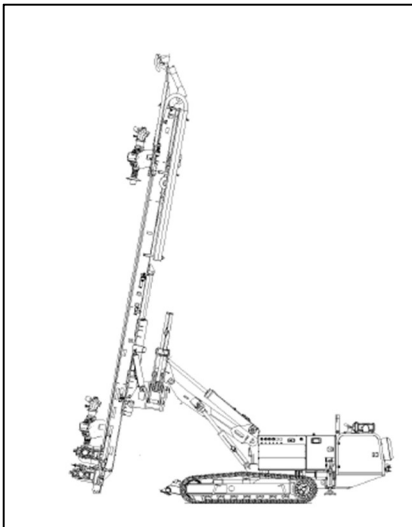

Definitions

Danger / Exclusion Zone: any area within and/or around a drill rig in which a person is exposed to risk of injury or damage to health. For a drill rig, this means the area in which a person can be reached by movement or the drill rig, its working devices, its auxiliary equipment or swinging or falling material.

Working Area: An area near a drill rig where its tools and or material are moved to carry out the installation of an anchor or micropile element.

Exposed Person: A person who is wholly or partially in the danger zone

Operator or Driller: A person operating the drill rig. They may also be the driver of the rig if it is a carrier mount.

Stability Angle: The angle between the vertical plane, passing through the tipping line and the plane passing through the center of gravity, and the tipping line. The stability angle thus defines the tilt angle to overturning.

Tramming: Traveling or tracking of a crawler mount drill rig on site.

Safety factor of rope: The ratio between the minimum breaking load of a rope by the manufacturer, and the maximum pulling force of a rope on the first layer of a winch.

Anchor/Micropile drill rig: A machine (sometimes known as a crawler drill) for drilling in soil or rock utilizing either percussive, rotary or vibration principles (or a combination of principles) which may involve the addition of drill rods, tubes, casings or augers etc., normally threaded, as the hole extends.

Assistant Chuck Tender: A person who assists with the drilling or foundation operation but is not responsible for control of the drilling or foundation equipment.

Tipping Angle: The angle a machine can be tilted before it becomes unstable while the machine is subjected to a system of loads (own weight, wind, accelerations, working loads).

Project Planning

General

Planning and preparation should be done early in the development of each project and include consultation with relevant participants such as the Owner, General Contractor (GC), Excavating Contractor, the Deep Foundation Contractor (DFC), along with overhead and underground utility authorities, geotechnical consultants, structural engineering consultants, and other relevant subcontractors. The deep foundation project should be considered in its entirety, when considering how to control risks and how many employees to engage.

Training of Employees

Employees of the Deep Foundation Contractor (DFC) must be informed and aware of Occupational Health and Safety matters that directly affect them. This includes identifying hazards and risks and determining risk controls. Employers should involve all employees in the development of safe work procedures such as hazard identification, risk assessment and risk control methods.

Site Management

Each employer on a given project needs to effectively manage the safety of their employees, material, and equipment. These duties remain even when they overlap with those of other employers.

For example, if a General Contractor (GC) has a supervisor on-site, the Deep Foundation Contractor (DFC) must still supervise their employees to ensure their work is being done safely. Deep Foundation Contractor (DFC) employers should have processes in place to effectively manage the work over which they have management or control, including processes to ensure:

- site-specific safe work practices are developed for other tasks where there is risk to employees or the public;
- Job Hazard Analysis are developed for all deep foundation work;
- employees are trained and knowledgeable of their assigned tasks and are directly supervised by competent employees;
- site conditions are monitored for known and potential risks;
- employee health, safety, and welfare is monitored.

Safety Management

The Owner and or General Contractor (GC), and Deep Foundation Contractor (DFC) should consult on the anchor / micropile works and agree on the responsibilities for managing safety for each activity associated with the work. The Owner / General Contractor (GC) should clearly identify who will be responsible for managing safety for each of these activities and coordinate with the Deep Foundation Contractor (DFC) to ensure the risks are effectively controlled.

Deep Foundation Contractors should develop plans and procedures to manage the works and associated risks, including:

- internal and external vehicle or equipment traffic
- loading/unloading of equipment, drill steel, casing, etc. (designating 'lay-down' areas for storage of materials)
- maintenance and operation of the anchor/micropile drill rig
- erection and disassembly of the anchor/micropile drill rig
- high risk construction work (develop a site-specific safety plan)
- operational safety and exclusion zones around anchor/micropile drill rig
- access to and around the site to reposition the anchor/micropile drill rig
- anchor/micropile drill rig working platform (design, certification and maintenance)
- falls from height and falling objects
- underground and overhead services (locating, marking, relocating, protecting or isolating) emergency procedures
- the effects of the anchor/micropile drill rig working near buildings, structures, or excavations
- movement of anchor/micropile drill rig into areas not visible to the operator
- protection of the public

Deep Foundation Contractors should also consider how many suitably trained workers they need to allocate for each activity.

Foundation Technique Selection

During the planning phase of the project, select the most appropriate foundation technique for the site. When determining the technique consideration should be given to all the site factors, including:

- plans and specifications
- requirements of the proposed structure and applied loadings
- ground conditions
- potential effects on surrounding structures

- environmental factors, such as nuisance to the public, effect on wildlife and their habitat, noise or vibration and waste products (i.e. drilling fluid, grout)
- site access, location and size
- proximity to existing assets, such as utilities, roads, railways and sensitive structures
- ground contamination
- water table

A competent person should assess the suitability of a specific anchor/micropile drill rig for the job.

Design of Working Platforms

A critical factor in any foundation technique is the surface required to support the anchor/micropile rig and ancillary equipment during operation or when moving about the site is a safe working platform. A working platform is defined as the surface at a construction site where piling and foundation equipment operates. The working platform is typically constructed from compacted soil, geotextile fabric, crushed rock, crane mats or a combination of each.



Example of a poor working platform

Inadequate working platforms can cause anchor/micropile drill rigs to become unstable and collapse with catastrophic results, including the potential for multiple deaths or injuries to Deep Foundation Contractor (DFC) employees, other people onsite and members of the public.

The Owner / General Contractor (GC), Deep Foundation Contractor (DFC) and other contractors must ensure the working platform is adequate, as all have legal duties associated with providing a safe workplace. During the planning phase consult and agree on

the minimum design requirements for the platform and ensure a competent person (e.g. a geotechnical engineer) designs the working platform.

A key factor of platform design is the maximum bearing pressure generated by the foundation drill rig or ancillary equipment. The Deep Foundation Contractor (DFC) must provide this information and other relevant equipment specifications to ensure a suitable platform is designed.

Equipment bearing pressure calculations should be based on those experienced during operational activities, rather than weight to track area that can be significantly lower than those experienced during operation.

Before using another rig other than the one designed for that platform, verify the rig is suitable for the platform. Due to weight to track area ratios, smaller rigs may have higher bearing pressures than larger rigs.

Ensure no Deep Foundation Contractor (DFC) works occur in areas where other site activities (e.g. trenching) have affected the integrity of the platform. Deep foundation work can only occur in the affected area when the platform has been fully reinstated and approved for use by a competent person.

The working platform should be monitored and maintained for the duration of the anchor/micropile work to ensure it does not deteriorate and continues to function as originally designed.

Communication between ground personnel, the rig operator, supervisors and other employees is essential and may include:

- Non-verbal - visual signals or audible signals (e.g. whistles) that cover the piling rigs functions. If using hand signals and ground personnel are out of view of the operator, they should be aided by an offsider (assistant or helper) to relay directions.
- Verbal - standard operational phrases or the optional use of a dedicated two-way radio system.

General Requirements for Anchor/Micropile Drill Rigs

Operator Training Requirements

If an employee is operating an anchor/micropile drill rig, the employee shall have a certificate of qualification or written proof of training. The training program shall include instruction on: the relevant requirements of applicable safety regulations; the drill rig manufacturer's operating manual; safe work practices; communications and signals; pre-operational inspections and checks; site assessment; drill rig set-up, securing and operation; and equipment maintenance.

Intended Use of the Anchor/Micropile Drill Rig

Ergonomics

The anchor/micropile drill rig shall be designed according to ergonomic principles to avoid fatigue and stress on the operator. Consideration shall be given to the fact that operators may wear heavy gloves, footwear and other personal protection equipment.

Hot & Cold Surfaces and Sharp Edges

Where there is a risk of human contact with hot or cold surfaces, such surfaces shall be protected by guards or cover.

Ventilating Ports

The mechanical ventilation and the cooling ports shall be provided with grills or similar devices to prevent fingers and limbs from reaching the moving components

Hoses, Pipes and Fittings Under Pressure

Pipes, hoses, and fittings shall be able to withstand the stresses from the pressure within. The hoses shall be marked with the rated working pressure.

Where there is a risk that a rupture of a hose or pipe at the operator's position could cause hazard to the operator, the hoses and pipes in this area shall be provided with protective guards.

Flushing hoses, such as air, grout and mud hoses, shall be secured against freeing themselves, by means of adequate restraints.

Handling of the Drill Rig and Its Parts

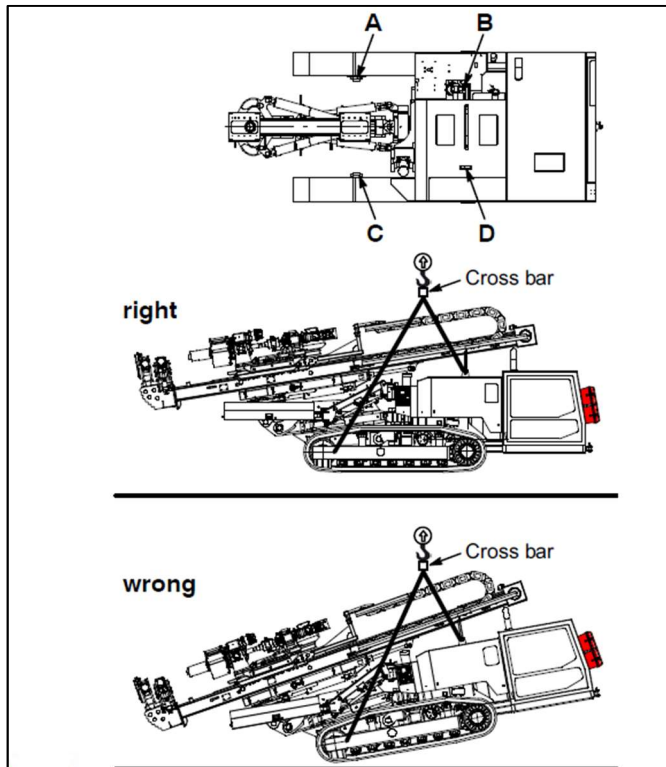

There are manufacturer defined lifting points of devices for lifting the whole or parts of the drill rig. They may also be used for holding and securing the machine during transport. Lifting points shall be clearly marked.

Components and parts of a drill rig which require it to be manually handled shall be designed in such a way as to allow safe manual handling.

If the weight and/or a form of components prevent safe manual handling, they shall be so designed by the manufacturer that lifting hardware can be safely used.

Access to Operating Positions and Servicing Points

Stairs, ladders, catwalks, footsteps, hand holds, support handles, guard rails, etc. shall be provided to allow access in safety to all areas for normal operation, adjustment and maintenance.

When doors, windows and flaps are designed to open and close freely, it shall be possible to secure them in both closed and open positions.

Isolation of Energy Sources

An anchor/micropile drill rig supplied with external energy (compressed air, water, grout, etc.) shall be fitted with means to isolate them from all energy sources. Such devices shall be clearly identified, and it shall be possible to lock them if reconnection could endanger exposed persons.



After the energy is shut off, it shall be possible to dissipate any energy remaining or stored in the circuits of the drill rig without risk to exposed persons.

As an exception from the above requirements, certain circuits may remain connected to their energy sources, e.g. to hold parts in

position, to protect information, to provide interior lighting.

Driving, Trimming and Operating Position

The driving, trimming and operating position(s) shall be designed and constructed so that all maneuvers necessary for the driving and operation of the anchor/micropile drill rig can be performed by the operator from the driving and/or operating position(s) without risk to themselves or to other persons in vicinity of the rig.

Operator's Position

Some anchor/micropile drill rigs may be provided with a cab to protect the operator against noise, dust and adverse weather conditions. There may however be types of drill rigs or operating conditions where it would not be appropriate or possible to provide a cab.

Drill rigs shall be designed for and fitted with Falling Object Protective Structure (FOPS) if they are specified for use in applications where there is a risk of rock fall.

Consideration shall also be given to protection against vertically and horizontally ejected objects, e.g. in the case using compressed air or water injection while drilling.

Controls, Functions, Systems

Starting

Starting of the drill rig's main power source shall only be possible by an intentional actuation of the starting control device. This shall also apply after a stop from whatever cause.

Unauthorized starting shall be prevented by the provision of suitable safeguards, e.g. lockable cab, lockable starting switch or lockable electric isolator switch.

If the drill rig has several starting controls, they shall be interlocked so that starting can only be carried out from one of the starting controls.

On a pneumatically powered drill rig, a main line valve shall be provided on the rig, which either connects the drill rig to the air supply, and when in the closed position shuts off the air supply and releases the air pressure in the rig system.

Stopping

Normal Stopping

The drill rig shall be fitted with a stopping device by which drilling is brought safely to a complete stop.

Emergency Stops

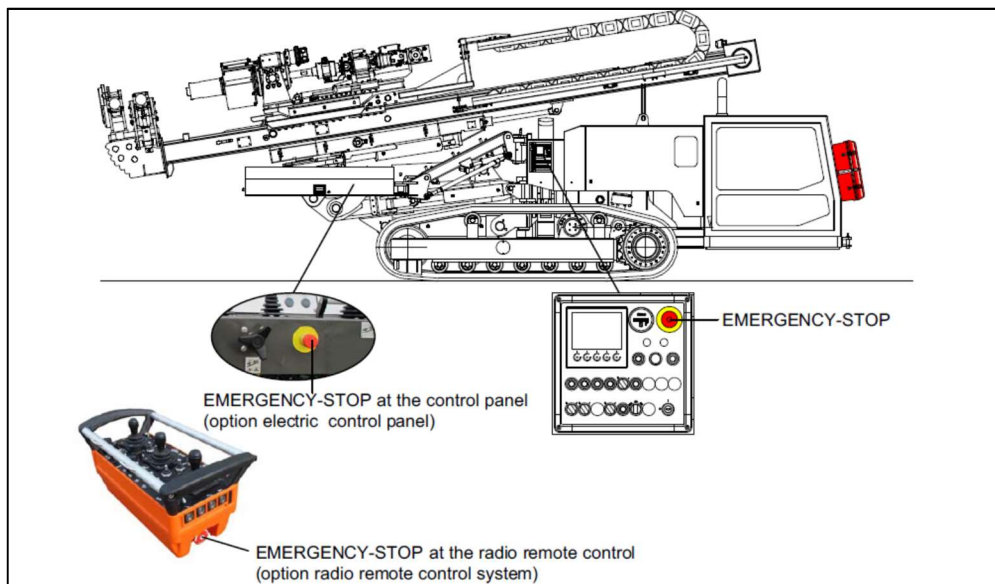

In order that an actual or impending danger be averted quickly, emergency stops shall be provided.

They shall stop all dangerous movements as quickly as possible to

prevent a dangerous situation developing without creating an additional hazard. At every operating or driving position there shall be an emergency stop.

The emergency stop devices shall be placed within easy reach of the operator. The emergency stop shall, after actuation, remain engaged until manually reset. This manual resetting shall not start the machine but only permit restarting by the normal starting procedures.

Failure of the Power Supply

An interruption of the power supply and a re-establishment after an interruption shall not lead to a dangerous situation, in particular:

- It shall only be possible to restart a drill rig by an intentional action;
- The drill rig shall not be prevented from stopping if the stop command has been given;
- No part of the machine or a tool shall fall or be ejected;
- Stopping, automatic or manual, or moving parts shall be unimpeded;
- Guards and other protective devices shall remain effective.

A power failure of a hydraulic or pneumatic pressure drop shall not cause any dangerous movements or actions. Such failures shall not stop the emergency stop systems from functioning.

Failure in a Control Circuit

A failure in the control circuit logic or in a control circuit shall not lead to a dangerous situation. The same safety requirements as stated above shall be fulfilled.

Control Devices

General

Control devices shall be marked without ambiguity in accordance with relevant standards and positioned for safe, quick and comfortable operation.

Control devices shall be designed so that their movement is consistent with their effect. All controls, other than those which control continuous operations e.g. drilling and casing operations, shall be of hold-to-run type.

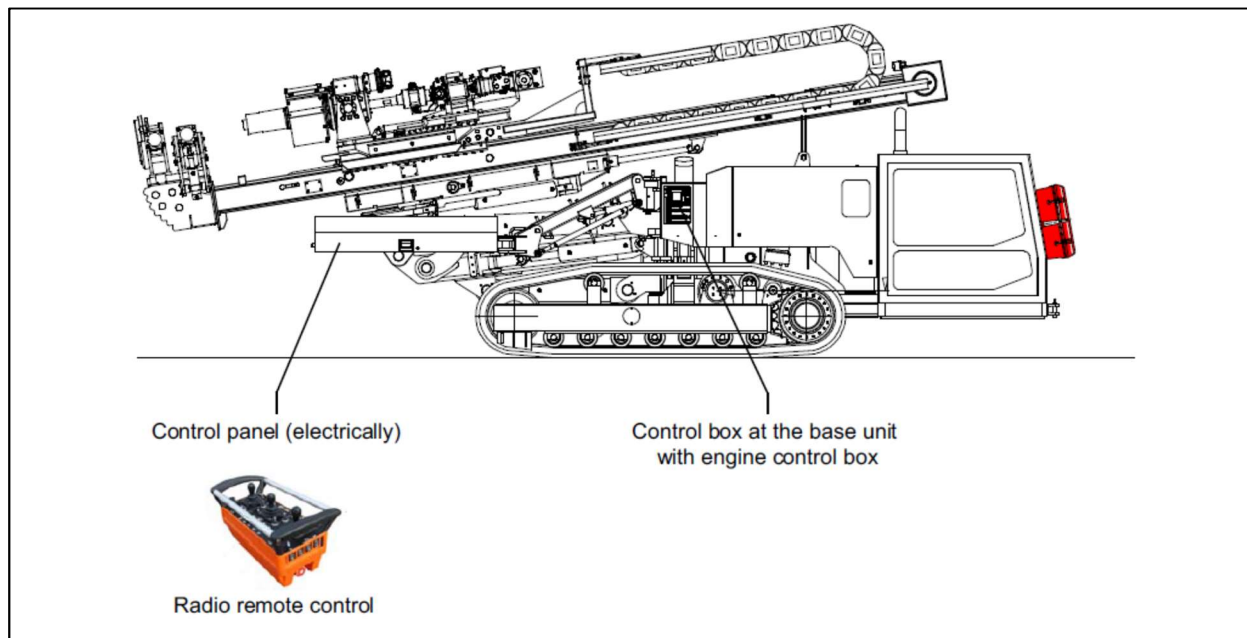

Control devices shall:

- When they are primary importance be within comfortable reach;
- When they are of secondary importance, be within normal reach;
- Where possible, be located outside the danger zone.

Where there is more than one operator's position (i.e. remote control), the drill rig shall be provided with a mode selector to intentionally select the control position which shall be used.

Many modern anchor/micropile drill rigs are equipped with a computer system which may monitor or control the operations of the drill rig functions. The monitor screens can be confusing at first, so the operator must familiarize themselves with the computer system.

Menu system pressures		
Screen	No.	Description
	1	Temperature cooling fluid diesel engine (°C)
	2	Engine speed
	3	Cleaning device active
	4	Rope winch active
	5	Option EEP-assist (Energy Efficient Power) Description EEP-assist see chapter 14.5 on page 157. Operation EEP-assist see description chapter 14.4.5.3 on page 144.
	6	Present mode (OFF, ROM, SPM)
	7	State of the safety device Touching the icon takes you to the menu "safety device" (see chapter 14.4.5.8 on page 151).
	8	Pressure drifter percussion
	9	Pressure rotation inner drill string
	10	Pressure rotation outer drill string
	11	Pressure feed function
	12	Pressure of the cylinder functions
	13	Pressure load compensation

Stability

General Stability Criteria

Drill rigs shall be so designed and constructed that they are sufficiently stable under the intended operating conditions, e.g. transport, tramping, parking and drilling and that there is no risk of overturning and falling. The stability shall be verified by calculation.

The stability angles listed within the manufacturer's operator's manual shall not be exceeded in any direction when tramping, drilling, or any other conditions.

When the drill rig is intended to work, tram or be parked on a plane deviating from the horizontal, the verification of stability shall include the maximum allowed slope angle under the most unfavorable conditions as specified and stated in the operator's instructions.

Instructions on stability and other essential restrictions of use which are of immediate importance shall be given on signs clearly visible at the operator's position, e.g. maximum allowed gradient angle for slopes when tramping or drilling.

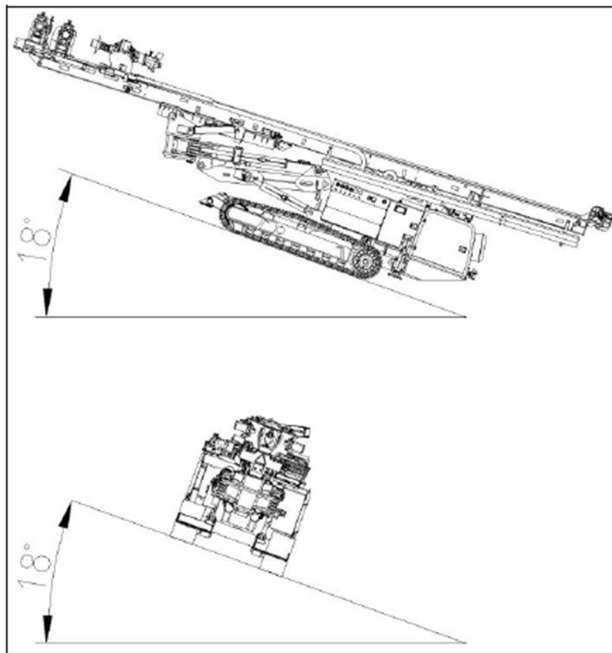

tipping line giving the lowest stability.

Detailed instructions regarding the restrictions and special measures to be taken when drilling, tramping or parking shall be given in the operator's manual.

Weights and positions of centers of gravity of single parts of the drill rig including the base machine, which have a significant effect on the stability and which are input data for the stability calculation, shall be verified by calculation and/or weighing.

The calculation shall be based on the drill rig standing on a firm plane with a mast inclination as specified and stated in the operator's instructions and for the

Dynamic Forces

For drill rigs having a rotating superstructure, the centrifugal force which acts on the center of gravity of the rotating masses, shall be considered in the calculation of stability.

Wind Force

The wind force shall be considered in the stability calculation. The wind force shall be assumed to act on the drill rig, including stacked drill rods and other equipment, adding to the overturning moment.

Other Working Forces

Other working forces that can influence the stability shall be considered when calculating the stability e.g.:

- The winch force between drill mast and drilling tool in the bore hole. The drill string and tool shall not be regarded as a support when only a rope is being used for pulling up the drilling tool.
- In the case of drilling down, the drill string may be considered as support.
- In case of upwards drilling it shall be checked that the available feed forces do not make the rear part of the drill rig lift.

Operating Conditions

Conditions that can affect anchor/micropile drill rig stability may include:

- Mast extensions, grout tubes / feed extension in advanced positions;
- Mast at the utmost front upward position and maximum forward mast inclination;
- Boom and/or mast articulation structures positioned side to side;
- Height of rotary head(s) when working on a batter;
- Compound Batters;
- Sudden starts and stops to mast position adjustment;
- Trimming with rotator at their highest position;
- Wind coming from the most unfavorable direction;
- Centrifugal force applied to the super structure;
- Maximum pulling force on drill steel and tool in the bore hole.

Stability of Anchor/Micropile Drill Rigs

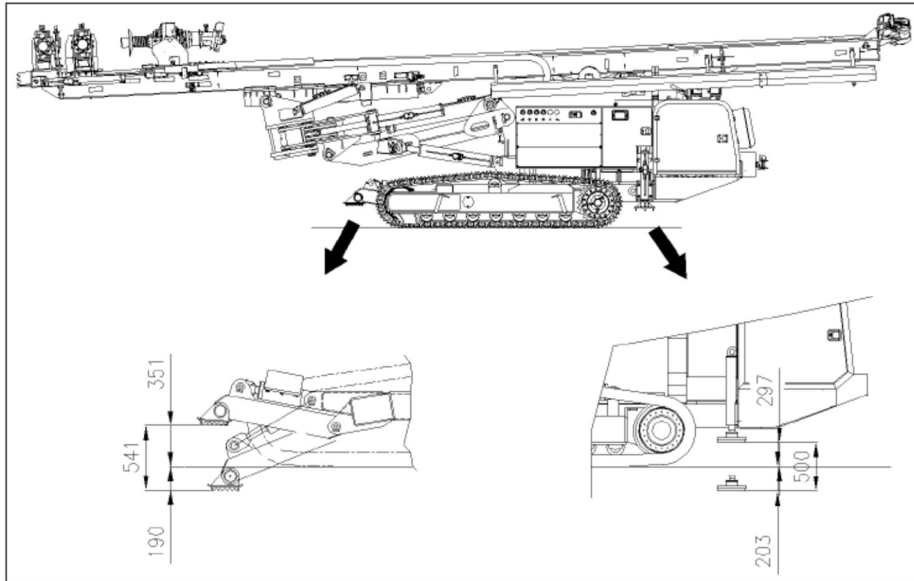

Some manufacturers require the use of front/rear stabilizers to provide extra stability during drilling operations. Consult operator's manual for the correct applications of their use, if the drill rig is so equipped.

Certain mast working positions may not be sustainable after raising outriggers to tram. Ensure the stabilizers are retracted before attempting to move the drill rig using the crawler tracks.

Service Braking Systems on Crawler Mounted Drill Rigs

Crawler drill rigs shall have either a service and secondary braking system, or two service breaks, one on each track. These shall be controlled individually e.g. by two separate control systems, one on each track. The braking system may be combined with the steering system.

One of the two fully independent braking systems is accepted as the secondary braking system in case of failure of the other brake.

The parking brake may be the same brake as the service brake if it is mechanically spring loaded for automatic braking action in case of loss of power supply.

Protection Against Moving Parts

General

The moving parts of a drill rig shall be designed, built and laid out to avoid hazards.

Compartments containing internal combustion engines shall be lockable. Movable covers, preventing access to such compartments need to have locking devices to prevent unauthorized access.

Danger Zones

The danger zone of the drill rig (when drilling on an angle or vertical) shall be a restricted access area when drilling and turning the superstructure of the drill rig. The drill rig should be provided with warning signs located on the most rearward parts of the machine.

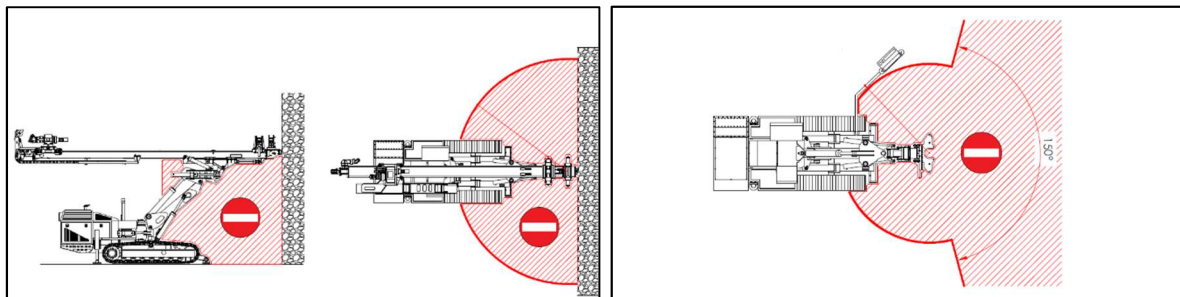

Electric Power Installation

An earth fault protection system shall be provided for electrically powered drill rigs.

Severe Weather

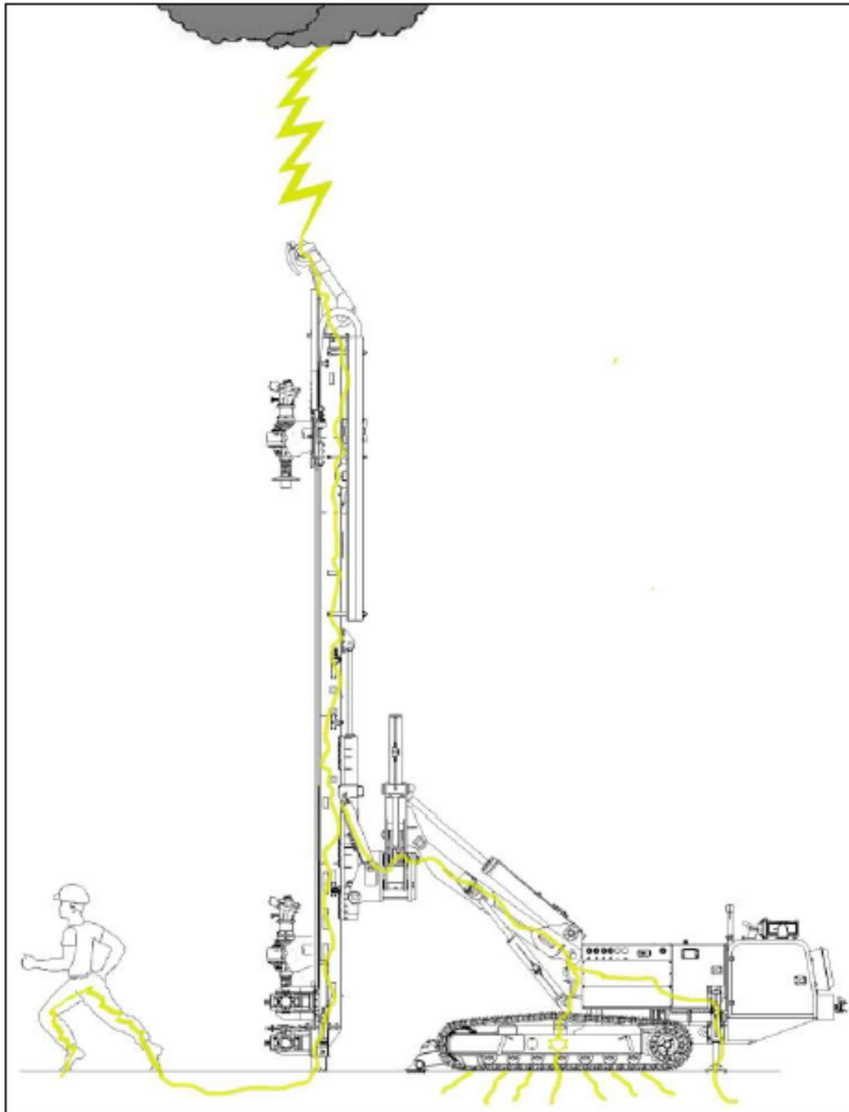

Exercise caution when lightning is in the area of operation. The drill rig is not insulated, and it will conduct electric current through the machine, and possibly to crew members.

All personnel should follow their employer's lightning safety protocol.

Battery Installation

The batteries shall be provided with lifting points and be firmly attached to their location. There shall be no risk of electrolyte splashing persons and surrounding equipment. The terminals must be fitted with protection from contact, and an isolator switch shall be fitted in the circuit.

Batteries and/or battery locations shall be designed or covered so that there is no risk to the operator caused by battery electrolyte or vapors even in the event of overturning of the drill rig.

Hydraulic Systems

Hydraulic cylinders used for erection and lifting shall be fitted with load sustaining devices mounted on the cylinder and shall be self-bleeding or fitted with an air bleed point at the highest point.

Flexible hydraulic hoses intended for pressures higher than 15 MPa shall be fitted with swaged fittings.

Hydraulic hoses and pipes shall be separated from electric power wiring and be guarded against hot surfaces and sharp edges.

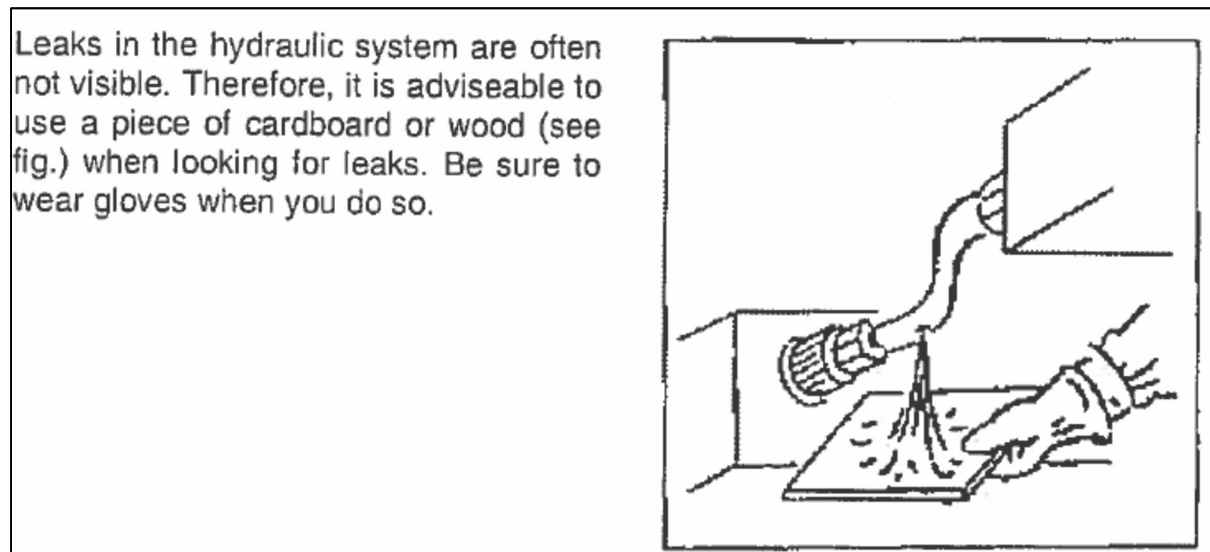

Pipes and hoses which must be disconnected in operation shall be fitted with self-sealing couplings with built-in check valves. Couplings shall be marked to ensure correct reconnection.

The tanks for hydraulic fluid shall be fitted with level indicators. The filling point of the tank shall be so designed that overflow is prevented when working on any gradient for which the drill rig is designed.

A temperature gauge or a monitor, which gives a warning signal if the allowed temperature is exceeded, shall be provided.

Auxiliary Winch

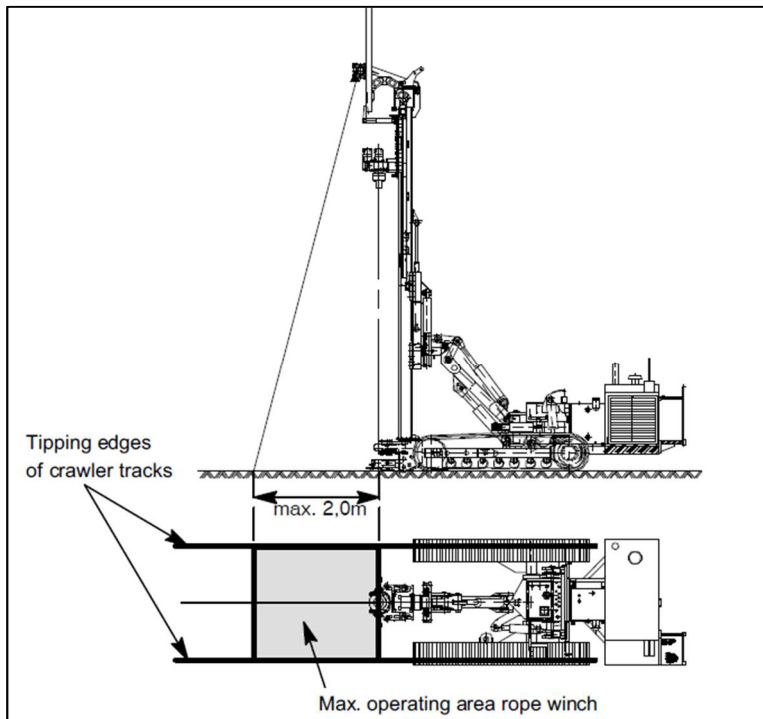

Do not exceed the manufacturer's load limits or operating parameters of the auxiliary winch and hoist line.

When lifting of a load with the winch rope operators must never make use of the mast positioning cylinder, or the stabilizers (outriggers) to increase lifting ability. The pressure relief valve may not be able to protect the winch from very dangerous overloads.

Tampering with the pressure relief valve for loads more than those allowed is prohibited.

Never misuse the winch cable to trail / traction heavy weights (e.g. bars, barrels, heavy pipes, reinforcement cages) to the drill rig.

The purpose of the winch is to mount accessories for drilling only within the maximum load area, and only with drill mast in vertical position. The drill mast / rope winch is not a crane. Winch may not be used for the direct or indirect transport or lifting of persons.

Feed Chain

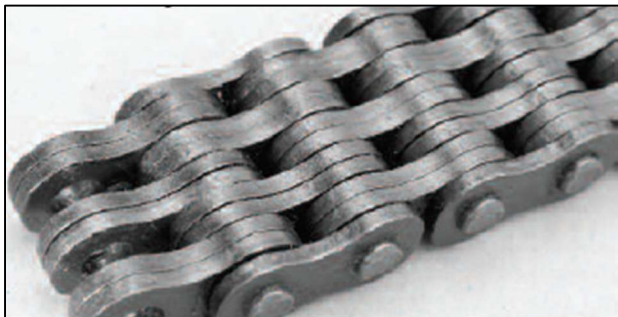

Check chains for cracks. Pins and links with wear marks and grooves or mechanical deformations must be replaced. The permitted elongation should not exceed 2%. Measurement must be done in the working area of the grease-free and cleaned feed chain under measuring load.

Flyer Chain

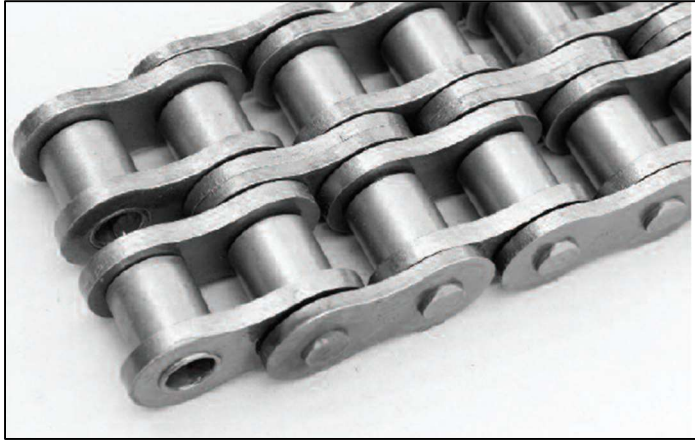

Roller Chain

If the permitted elongation is exceeded, the chain is not useable, and must be replaced.

The feed chain must always be cleansed of coarse dirt. Build-up of coarse dirt deposits or rocks on the chain can lead to overstretching or rupture of the chain when rolling over the chain deflection of the mast. Maintain feed chain tension according to the manufacturer's requirements.



In certain circumstances, it is possible for the feed chain connection to fail. This may cause the drill motor to rapidly travel down the mast, and possibly strike an employee, especially when drilling in a vertical position.



This image shows a feed chain with stretch damage. Notice how the links are distorted.



This image shows excessive wear to the feed chain, and dirt/grout contamination and a lack of lubrication.

Warning devices

Warning devices such as signals, etc. shall be unambiguous and easily perceived. The operator shall have the facility to check the operation of all essential warning devices at all times.

There shall be a manually operated, audible alert signal to warn personnel in the working area of impending danger. It shall be possible to operate the audible warning for each driving or operating position including (if applicable) a remotely situated monitoring position. There shall also be an automatic, audible or visual warning signal given when reversing.

Set-up and Operation

Location







After consulting with the Owner / General Contractor (GC), the Deep Foundation Contractor (DFC) should ensure the location selected for the equipment set-up is suitable, considering whether:

- the area is accessible, and any slopes are within the operating capacity of the equipment;
- the surface is firm, able to support the weight of the operating anchor/micropile equipment and any delivery trucks;
- the area is clear from obstructions and excavations;
- the equipment can be operated without encroaching the 'no-go zone' areas near overhead powerlines;
- underground services or buried structures are identified;
- an effective operational safety zone can be established;
- any public protection needs to be implemented.

Locating Underground Utilities

1. The Deep Foundation Contractor (DFC) must be aware of all services that may affect the work or that maybe located in the work zone and have a valid copy of all locates.

2. Locates shall be obtained prior to commencement of drilling by contacting the utility locate service ((contact information varies) and additionally any utility owner that is not associated with a one call system. Locates may only valid for a specified amount of time from the date of issue. Always refer to the special instructions section of the utility locates for further instruction from the utility owner.

	Red - Electricity
	Yellow - Gas, Oil, Steam, Chemical
	Orange - Communication, CATV
	Blue - Water
	Green - Sewer, Storm Drain
	Pink - Temporary Survey Markings
	White - Proposed Excavation

3. Proof that locates were completed are required on site for the duration of the project.

4. Clearly marked stakes, flags or paint will indicate the location of various underground utilities.

5. In the case of any uncertainty as to specific location of underground utilities, excavation, drilling of piles is not to commence until

the service is exposed or located by hand (shoveling) or other means (e.g. hydrovac).

6. The underground utility must be located by hand excavation and visually inspected if located close to the work area. If the located utility stakes or paint is within a distance equal to the stake-out tolerance (typically 1m) then hand-excavated test pits shall be required prior to commencement of deep foundation work.

7. Services that are known to be close to the deep foundation elements may require some type of special protection. Contact the appropriate utility owner to agree on such protective measures.

8. If unanticipated underground utilities are encountered, work shall cease at that location until the utility and its owner has been identified and it has been deemed safe to continue.

Equipment

Ensure all anchor/micropile drill rigs and auxiliary equipment are in a mechanically sound condition and have:

- comprehensive operator's instructions or the manufacturer's operation manuals;
- correctly positioned and legible warning/safety signs or stickers;
- all required safety equipment fitted;
- an adequate supply of packing for any stabilizer base plates;
- current equipment risk assessment;
- up to date equipment maintenance logbooks;
- required registration or DOT/interstate equivalent.

Loading - Unloading Equipment



When loading or unloading a drill rig on a trailer or a truck, follow these precautions:

- Determine that the trailer is the proper type for the drill being loaded.
- Select an area of level ground for loading and unloading.
- Have a spotter guide the driver on / off the trailer or truck.
- Before using a ramp, verify the brakes of the drill rig are in working order.
- Ensure that any ramps used are designed for this purpose and provide a sturdy and solid enough base to bear the weight of the drill rig with carrier including tooling.
- Verify that when the drill rig is on the trailer, the weight of the drill rig, carrier and tools are centered on the centerline of the trailer. In addition, some of the trailer load should be transferred to the hitch of the tow vehicle. Refer to the trailer recommendations for weight distribution provided by the manufacturer.
- Verify the drill rig is secured to the towing vehicle with ties, chains, or load binders that can handle the required weight.

Assembly and Disassembly of Anchor/Micropile rigs

The Deep Foundation Contractor (DFC) should develop or have access to detailed procedures for the assembly and disassembly of the foundation drill rig. These procedures should be based on:

- the manufacturer's recommendations
- controlling the risks of working at height
- working around powered mobile equipment
- ensuring the foundation drill rig structural stability during the process
- verification that the equipment is correctly assembled

EXTENDING THE CRAWLERS



Tipping hazard!

The crawlers must be extended as soon as the machine has been unloaded from the transporting vehicle and before rigging operations are begun.

A JHA (Job Hazard Analysis) must be developed before work starts and followed during the assembly or disassembly process.

Employees must be appropriately trained and instructed in the assembly or disassembly procedures for the specific foundation drill rig and supervised to ensure they work safely.

Exclusion Zones

Establish an exclusion zone around the drilling operations to keep activities separate from other onsite construction activities and to separate mobile equipment from people. Only those involved in the drilling operations should enter the exclusion zone. Precautions should be in place to prevent unauthorized persons or mobile equipment from accessing the safety zone area.

Exclusion zone zones should be clearly marked by a physical barrier and signage. If a physical barrier is not reasonably practical, the operational safety zone boundary should be indicated with appropriate signage warning people to keep out.

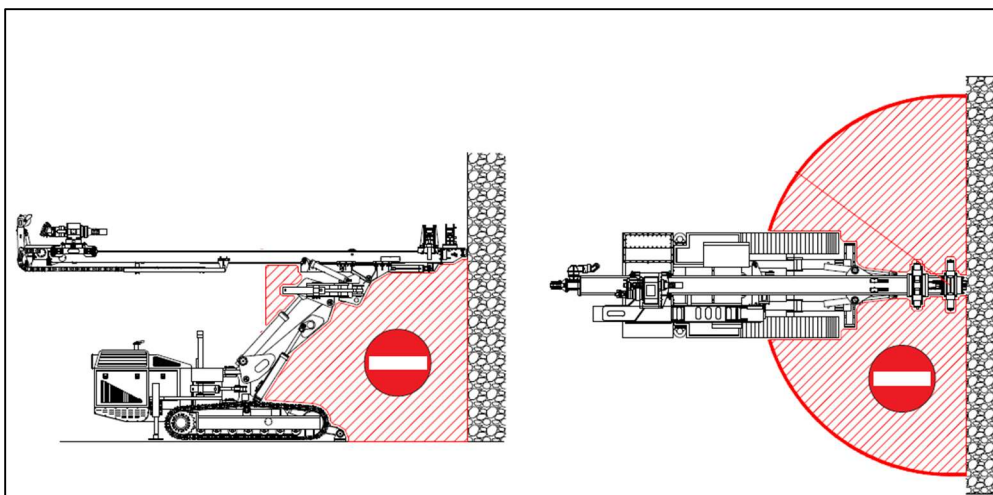

The danger zone of the drill rig (when drilling on an angle or vertical) shall be a restricted access area when drilling and turning the superstructure of the drill rig.

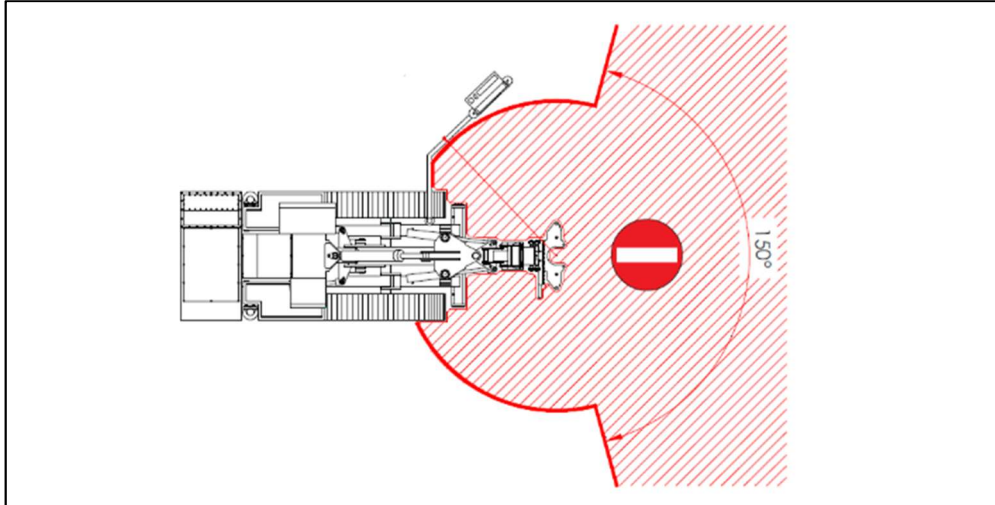

The drill rig should be provided with warning signs located on the most rearward parts of the machine.

The exclusion zone must be included as one of the controls for working in the vicinity of an anchor/micropile drill rig in the site-specific safety plan.

Powerlines and Electrical Equipment

Overhead Powerline Safe Working Clearance:

Note - Anchor/Micropile Drilling Rigs are not considered to be nor defined as “Cranes” in the US and Canada. However, in the following resources, the reader will note that there are numerous references to mobile cranes and not dedicated drill rigs per se. As a best practices precaution, the safe working distances and warning procedures noted for mobile cranes per OSHA CFR 1926.1409, must be applied to the use of dedicated drilling rigs - of any type.

Table A – Minimum Clearance Distances	
<i>Voltage (nominal, kV, alternating current)</i>	<i>Minimum clearance distance (feet)</i>
<i>up to 50</i>	10
<i>over 50 to 200</i>	15
<i>over 200 to 350</i>	20
<i>over 350 to 500</i>	25
<i>over 500 to 750</i>	35
<i>over 750 to 1000</i>	45
<i>over 1000</i>	<i>(as established by the power line owner/operator or registered professional engineer who is a qualified person with respect to electrical power transmission and distribution)</i>

When operating a foundation drill rig near overhead powerlines the site-specific safety plan must detail the safe working procedures, and the requirements of the minimum clearance distances to be observed.

No part of an anchor/ micropile rig or its load should come closer than 10 feet (3.05 metres) of an energized powerline.

As the voltage increases, the safe clearance distance also increases - see Table “A” for reference.



Ensure excavation works or working platform construction does not alter ground levels or reduce safe clearances under powerlines.

Equipment, Inspection and Maintenance

General

Regular inspections and preventative maintenance of a foundation drill rig and auxiliary equipment are essential for the safe and efficient operation, and to ensure mechanical integrity of all components. Failure of key components may cause an incident and possible collapse of the rig or its parts.

A maintenance and inspection program should consider the equipment's working environment and usage. It should be based on the manufacturer's recommendations or designed by a competent person to either achieve the same safety outcomes or compliance with the relevant construction safety standards.

The maintenance program should include:

- pre-operational inspections and tests;
- routine inspection, servicing and maintenance at specified intervals;
- periodic/annual inspections;
- major inspections at specified intervals;
- all items listed in the manufacturer's manual.

The following should be recorded in the equipment's service book and in more detail in the maintenance records:

- inspections and maintenance;
- defects found, and repairs undertaken;
- structural alterations.

Note: A copy of the manufacturer's manuals should be kept in the foundation drill rig, or onsite in a safe area. Contractors should ensure service records and maintenance manuals are maintained, kept in a safe and accessible place.

Pre-Operational Inspection

A pre-operational inspection of all relevant items indicated in the operations and/or manufacturer's manual should be done prior to the start of each shift and include inspecting and/or testing for:

- equipment access
- clear visibility from the operator's position
- operating and emergency controls
- feed chain, sprockets, motor

- safety switches and interlocks, including limiting and indicating devices
- visual inspection of the structure, including pipelines and connections (where applicable)
- wire ropes to ensure they are on the drum, correctly reeved on the sheave and in good condition
- mast cylinders
- fluid levels
- battery
- hydraulic system & hoses
- jaw clamps
- rotator / hammer
- crawler tracks / tension
- grout / discharge swivel
- electric motor/power supply cord/grounding
- auxiliary power unit
- auxiliary crane
- rod carousel
- ground conditions/safe working platform

Routine Maintenance

All anchor/micropile drill rigs should be inspected and maintained by a competent



person at intervals specified in the maintenance program.

The competent person should ensure the maintenance is done to the manufacturer's requirements and the specified items are inspected and/or tested.

Specified items include:

- emergency devices
- operator controls
- components associated with lifting (e.g. wire ropes and sheaves)
- interlocks and travel limiting devices

- access to the machine for operation and maintenance
- critical components (e.g. brakes, gears, fasteners, pins and shafts)
- track wear
- areas affected by corrosion, damage, wear or abrasion
- drill rig and its components after transportation (e.g. return from site)
- metal fatigue in critical wear or stress points
- additional items required for inspection by the manufacturer

The results of the inspection must be entered in a logbook and kept with the drill rig. All safety-related faults must be reported and corrected before the piling rig is used and recorded at an appropriate time.

Annual Inspection

A competent person should inspect each anchor/micropile drill rig at least every 365 days. The competent person's inspection should review the routine maintenance reports and verify any identified defects and faults have been repaired. The competent person should inspect all high stress areas, critical mechanical and structural components, including visual, selected strip-down and other testing (e.g. nondestructive testing) as required or necessary to make an accurate assessment of the rig's condition.

To ensure the anchor/micropile drill rig is safe for continued operation it should be inspected and tested based on the rig's age, usage and known critical wear areas or components. In the absence of verifiable records of previous maintenance, inspection repairs or modifications, the anchor/micropile rig should be assessed to its suitability for continued service.

Competent Person for Inspection

A competent person should have the knowledge, skills and the experience necessary to accurately assess the condition of the equipment and its components. Different skill sets may be required depending on the inspection criteria or the components being inspected. The competent person could be an independent consultant, the rig manufacturer or their designated representative, or a person employed by the owner of the rig.

Repairs

Any repairs made to equipment should be done according to the manufacturer's maintenance and repair manuals or detailed instructions from a competent person. All repairs and any replacement of components should:

- be carried out by a competent person
- use Original Equipment Manufacturer (OEM) parts or those that are compatible with OEM and with at least the same specifications
- be recorded in the service book and detailed in the maintenance records

Welding

Welding of load bearing components should be done by a suitably qualified welder and recorded in the service book and detailed in the maintenance records.

Note: For anchor/micropile rigs with on board computer systems - it is essential that the manufacturer's procedures with respect to battery disconnection be strictly followed. If not followed, then severe electronic damage can occur at the first strike of an arc.

Equipment Modifications

The modifier of the equipment may take on legal obligations of designer, manufacturer and supplier when they alter the equipment; including doing a risk assessment and providing safe use information.

Modifications to road carrier vehicles need to comply with the requirements of the Department of Transportation. Engineering calculations may need to be done to verify the modifications comply with relevant technical standards and associated strength and operational requirements. Modifications with the potential to affect safe operation of equipment should be approved in writing by the manufacturer or a qualified mechanical engineer. Engineering calculations and approvals should be kept for the life of the equipment.

Maintenance Records

Maintenance records should:

- clearly describe the work undertaken and parts replaced
- record the date of inspection and maintenance
- note who did the work and any recommendations for the preventative maintenance program register
- be signed by the person carrying out the work
- be kept for the life of the equipment
- be readily available

Drilling Operations

Drilling Equipment Using Threaded Drill String Connections

A powered drill rod break-out system shall be installed on anchor/micropile drilling equipment equipped with top hammers/percussive mechanism, and or rotary top drive using threaded drill rods.

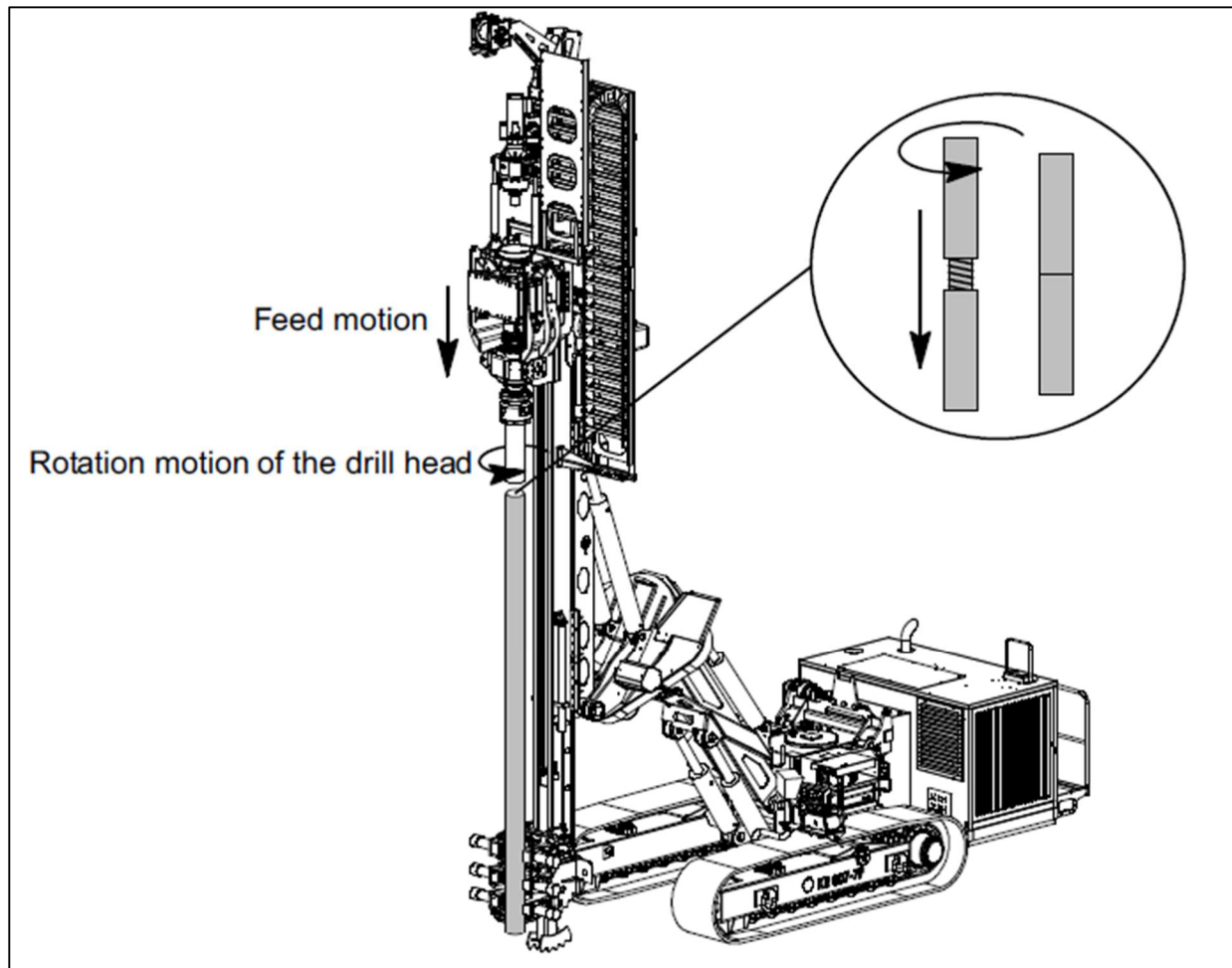

Clamps and Rod Breaking Clamps Used in the Drilling Process

All mechanical or hydraulic rod clamps and rod breaking clamps shall be designed and equipped to protect against the hazards during operation and maintenance of:

- entrapment
- shearing
- crushing

Components of the equipment can be damaged by an improper use of the clamping and breaking devices with locking brackets. The at the equipment mounted clamping and breaking devices with locking brackets must only be used in accordance to the following instructions.

▲ If clamping- and breaking devices are equipped with locking brackets, these brackets must be closed and locked during operation. The locking brackets are used to take up the clamping forces and to avoid bending of the device housing.

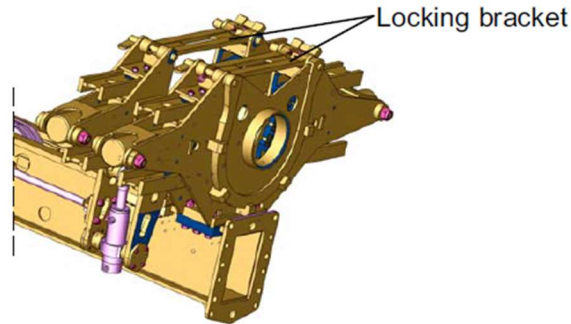

Note: One example may be “hold to run” controls with full visibility of clamps etc. from control panel

Falling or Ejected Objects

Drilling and foundation equipment shall be designed, constructed and equipped to prevent objects that could cause injury from falling or being ejected towards persons. Falling, or ejected objects include:

- air flush cuttings, excavated material, dust;
- machine parts/components or fragments of machine parts/components;
- tools or fragments of tools.

Anchor/micropile drill rigs using either compressed air or air mist as a flushing agent shall be fitted with a system to prevent injury to persons from ejected material or dust, e.g. dust collectors, diverters/deflectors etc.

Safety Device for Stopping of Rotation and Feed

Where there is a risk that personnel can be caught and injured by the rotating member, the drill rig shall be equipped with additional trip devices in the immediate area of the rotating drill string accessible to personnel. The trip devices shall be installed and equipped so that they will be automatically actuated in an emergency

by the body or part of the body without any delay or difficulty. The trip device actuators shall be clearly marked.

If the drill rig is equipped with a mechanical drill rod/pipe handling system, a trip device on the free side of the drill rod/pipe is sufficient.



Trip Device parallel to mast

When actuating the trip device, any residual energy in the system shall be contained or released so as not to cause any dangerous movements.

The trip device shall after actuation, remain engaged until manually reset. This manual resetting shall not start the machine but only permit restarting by the normal starting procedures.

If such a trip device is not feasible, due to operational reasons, the danger zone shall be a forbidden access area when drilling and performing other hazardous operations. The forbidden access area shall be provided with “No Access” signs, and only trained and authorized employees are permitted to work in this area.

Field Operations - General

The first requirement for safe field operation is that everyone must understand and fulfill the responsibility for maintenance and housekeeping on and around the drill rig.

Suitable storage locations should be provided for all tools, materials, and supplies so that tools, materials, and supplies can be conveniently and safely handled without hitting or falling on a member of the drill crew or a visitor, without creating tripping hazards, and without protruding at eye or head level.

Avoid storing or transporting tools, materials, or supplies within or on the mast of the drill rig.

Pipe, drill rods, casing, augers, and similar drilling tools should be stacked orderly on racks or sills to prevent spreading, rolling, or sliding.

Work areas, platforms, walkways, and other access ways should be kept free of materials, debris, and obstructions and substances such as ice, grease, or oil that could cause surfaces to become slick or otherwise hazardous.

Keep all controls, control linkages, warning and operation lights, and lenses free of oil, grease, and ice.

Dirty or contaminated pipe, drill rods, and augers, should be moved away from the work area to prevent possible exposure to non-protected personnel and to prevent cross-contamination of clean materials.

Wastewater and drilling fluids must be properly contained and labeled and stored out of the operational area.

Remove and dispose of empty bags or other containers, which have held drilling mud, cement or other dust producing materials.

Do not leave items such as hand tools, rakes, shovels, or other small equipment lying on the ground as they would pose a trip hazard.

Never use compressed air for cleaning clothes.

All unattended boreholes must be adequately covered or otherwise protected to prevent personnel, site visitors, or animals from falling into the hole. All open boreholes should be covered, protected, or back filled adequately and according to local and state regulations or customer requirements upon completion of the drilling project.

Walk around, not over, obstacles. Carefully choose a walking path to avoid ruts and steep slopes. Walk around freshly placed fill, gravel, or rip-rap. Keep eyes on the path.

Drilling

Considerations during general operation:

- No visitors are permitted near the work area without proper protective clothing and authorized permission.
- Only personnel necessary to achieve drilling objectives should remain within the exclusion zone. All others should remain outside the exclusion zone.
- Effective communication (hand signals), especially under high noise conditions, is essential to safety. Clarify use of hand signals.
- If the operator of the rig must leave the area of the controls, the operator should shift the transmission controlling the rotary drive and the feed control to neutral.
- All crew members should be familiar with basic controls of the rig, including how to stop the engines, align the Kelly with the borehole, raise and lower the drive head, raise and lower hoists, and chuck or unchuck the rods.
- Do not climb the rig mast while an anchor/micropile rig is running. Shut down/lock out the rig and use full body safety harness if climbing mast is necessary.
- The operator of a drilling rig should only operate the rig from the position of the controls.
- The operator should shut down the drilling engine before leaving the vicinity of the drilling rig.
- Drilling should always proceed cautiously, especially at depths less than ten feet.
- Operation of drilling equipment should be limited to qualified personnel.
- Do not exceed the manufacturers' technical specifications for items such as speed, force, torque, pressure, and flow.
- If drilling in an enclosed area, make certain the exhaust fumes are vented from the work site.
- If drilling with air, direct the exhaust and cuttings away from the workers.
- Never operate the drill rig with any of the machinery guards removed.

- Drill rods and sampling barrels should never be left unsecured, leaning against or balanced across the drill rig.
- Never exceed the pipe and rod racks design maximum load.
- Always make provisions to prevent stock from accidental rolling.
- Attach safety chains or cables swivel, air, and other pressure hoses.
- When cranking pumps or other motors keep head well back of the crank area to avoid being hit when motor turns over.
- Fugitive dust control is to be used during dry drilling, especially in potential areas of naturally occurring asbestos and silica.

Considerations when adding and removing drill rod:

- Only the drill operator will break or set the chucks, to eliminate the possibility of engaging the transmission prior to removing the chuck wrench, if used.
- Check the chuck jaws periodically and replace them as necessary.
- Never place hands on wrenches where they can get trapped between the wrench and the drill rig.
- Ensure that wrenches are removed, and/or jaw clamps are released from rods before starting to drill.
- Do not take hold of the male thread end of drill rod. Watch for sharp burrs on rods and casing, and file sharp edges off rods when necessary.
- The operator must know the capacity of the hoist and mast, and the weight of the drill rod, to prevent the hoist capacity from being exceeded.
- The drill rig operator must exercise care to lower the hoist slowly while the drill rod is being carried away from the hole.
- There should always be at least three wraps of hoisting line on the hoist drum to prevent a line load from being applied directly to the fastening clamp.
- Do not guide or hold onto moving wire line work cables with bare hands.

Operating the Drilling Rig

Only employees will operate the drilling rig or handle equipment associated with drilling operations, including winches, augers, drive rods, ropes, and cables. Operators, field personnel and any visitors must be aware of the location of the emergency shut-down/kill switches and operation of these devices, and the devices must be in safe working condition prior to the start of the project and thereafter.

The Operator should never leave the controls of the drilling rig while the tools are rotating unless all employees are clear of rotating equipment.

During drilling operations, the Operator at the controls must be aware of the Helper's position and actions at all times. Operation of the winches and or rotary actions should only occur once the Operator has visually or verbally confirmed that the Helper is all clear. During assembly operations (auger attachment or rodding connection), no

mechanical operations should occur until body position or hand placement is confirmed to be in a non-pinch or crush position.

No employee is to reach into or near pinch points, the borehole, or the rotating equipment, unless the drilling rig has been shut down.

Working on the Mast - General Repairs

Drillers should not climb the mast to make repairs if the mast can be lowered. If the mast cannot be lowered to make repairs, workers may use a ladder or may climb the mast if proper fall protection, such as a harness and attached lanyard, is available and used. Fall protection devices, in the form of a harness and lanyard, will be used where workers are 6 feet or greater in height (if a ladder or personal lift is not available). No one should climb the mast to make repairs while the drilling rig is operating.

During general repairs or maintenance actions, employees must also consider extra caution with respect to hand tools and potential slippage actions. Keep tools clean and free of grease and oils, plus thoroughly clean any bolt heads or parts before wrenching. These actions may prevent slippage and possible hand injuries. Where possible, leather gloves should be worn (cotton gloves may be worn where dexterity is an issue).

Pressurized Systems

No repair or maintenance will be performed on pressurized systems unless all pressure has been relieved.

Extreme caution will be used when opening any valve.

All relief valves will be installed so that any discharge will be directed away from workers and equipment.

Any extensions necessary for proper venting of relief valves will be secured against whipping and incorporate whip checks.

Acknowledgments:

The authors wish to acknowledge and thank the following organizations for their support in the development of this manual:

- ADSC: International Association of Foundation Drilling
- Bauer Foundations Australia Pty Ltd
- Bauer Maschinen GmbH
- BRC Piling & Foundations Pty Ltd
- Casagrande S.p.A.
- Construction, Forestry, Mining & Energy Union (CFMEU)
- Frankipile Australia Pty Ltd
- Geotech Pty Ltd
- Master Builders Association of Victoria (MBAV)
- NAIT: Northern Alberta Institute of Technology
- NCCCO: National Commission for the Certification of Crane Operators
- Ontario Association of Foundation Specialists
- OSHA - Occupational Safety and Health Administration
- Piling and Foundation Specialists Federation (PFSF)
- Piling Contractors Pty Ltd
- Soilmec S. p. A.
- Vibro-pile (Aust.) Pty Ltd
- Victorian Construction Safety Alliance (VCSA)
- Wagstaff Piling Pty Ltd
- WorkSafe Victoria

Appendices:

DEFINITIONS:

DANGER/WARNING/CAUTION

DANGER

[Indicates an imminently hazardous situation which; if not avoided, will result in death or serious injury.]

! WARNING













[Indicates a potentially hazardous situation which; if not avoided, could result in death or serious injury.]

! CAUTION

[Indicates a potentially hazardous situation, which; if not avoided, may result in minor or moderate injury.]

CAUTION

[Indicates a potential for property damage.]

1		LIVE ELECTRIC PANEL
2		NO ADMITTANCE TO UNAUTHORIZED PERSONNEL
3		HIGH TEMPERATURE
4		TOXIC FUMES
5		ACCESS PROHIBITED TO WORK AREA
6		PRESSURIZED FLUID
7		COMPLIANCE WITH SAFETY DISTANCES
8		MACHINE MAINTENANCE IN PROGRESS: DO NOT START!
9		IT IS FORBIDDEN TO WALK ON THE SURFACE
10		EMERGENCY EXIT
11		READ THE INSTRUCTIONS AND WARNINGS ON THE MAINTENANCE AND USE MANUAL
12		LIFTING POINTS

2.10 Meanings of machine-specific signs



Warning indicating rotating machine parts



No access for unauthorized personnel



Danger of crushing



Warning indicating dangerous electrical voltage



Warning of bodily injury

Resource Material Available Without Cost:

The following resources / links are available for free using the Internet links provided:

Overhead Powerline Safe Working Clearance:

<http://www.hydroone.com/SiteCollectionDocuments/Safety/ZapZonePamphlet.pdf>

https://www.workzonesafety.org/files/documents/news_events/wz_conference_2002/avoiding_contact.pdf

<http://www.penticton.ca/assets/Departments/Documents/ElecticalSafety-HighVoltage.pdf>

https://www.osha.gov/pls/oshaweb/owadisp.show_document?p_table=STANDARDS&p_id=19

Note: Dedicated Drilling Rigs are not considered to be nor defined as “Cranes” in the US and Canada. However, in the following resources, the reader will note that are numerous references to mobile cranes and not dedicated drill rigs per se. As a best practices precaution, the safe working distances and warning procedures noted for mobile cranes, must be applied to the use of dedicated drilling rigs - of any type.

Underground Utility Location:

<http://albertaonecall.com/learning-centre/color-code-explanation/>

<http://call811.com/best-practices/best-practices-guide/uniform-color-code>

<http://www.clickbeforeyoudig.com/>

<http://call811.com/811-your-state>

Rotary Foundation Drilling Rig Safety:

<http://www.hse.gov.uk/foi/internalops/og/og-00055.htm>

<http://www.oafs.org/downloads/SafetyProcedures.pdf>

<https://pilingfederation.org.au/>

Construction Safety Regulations:

OSHA - Occupational Safety & Health Administration

https://www.osha.gov/pls/oshaweb/owasrch.search_form?p_doc_type=STANDARDS&p_toc_level=1&p_keyvalue=Construction

US Army Corps of Engineers Safety and Health Requirements Manual

<http://www.usace.army.mil/Safety-and-Occupational-Health/EM-385-1-1-2008-Being-Revised/>

The Federation of Piling Specialists

<http://www.fps.org.uk/>

The National Institute for Occupational Safety and Health (NIOSH)

<https://www.cdc.gov/niosh/construction/>

Canadian Centre for Occupational Health and Safety - Links to Provincial Requirements

<http://www.ccohs.ca/oshanswers/information/govt.html>

Canada National Occupational Health and Safety Regulations

<http://www.laws-lois.justice.gc.ca/eng/regulations/SOR-86-304/index.html>

Education:

Northern Alberta Institute of Technology (NAIT) Foundation Drill Rig Operator Program

http://www.nait.ca/program_home_103029.htm

Rigging Information:

Crosby Group

<http://www.thecrosbygroup.com/catalog/rigging-information/>

National Commission for the Certification of Crane Operators (NCCCO) Reference Manuals

<http://nccco.org/nccco/safety-information-research-education-network>

Resource Material Available for Purchase:

The following resources are available for purchase using the Internet links provided.

European Standards:

EN 16228-1 Drilling and foundation equipment - Safety - Part 1 - Part 7

https://www.en-standard.eu/csn-en-16228-1-drilling-and-foundation-equipment-safety-part-1-common-requirements/?gclid=EAlaIQobChMlyMLW4Mbe1QIVUoGzCh1SNAkNEAAYASAAEgKMH_D_BwE

American Society of Safety Professionals (ASSP):

ANSI/ASSE A10.23-2014 - Safety Requirements for the Installation of Drilled Shafts

<http://www.asse.org/ansi/asse-a10-23-2014-safety-requirements-for-the-installation-of-drilled-shafts/>

ADSC: The International Association of Foundation Drilling:

<http://foundationdrillingmagazine.com/tlc17/index.html>

- Down-Hole Entry Manual: Recommended Procedures for the Entry of Drilled Shaft Excavations
- Drilling Operators Machine Safety Guide
- Recommended Procedures for Fall Protection in Shaft Excavation Operations
- Anchor and Micropile Installation Safety Guide